

Diameter Solution Suite™ Use Case

HSS, PCRF and OCS/OFCS Load Balancing and Binding Intra-PLMN (Home)

Problem

The Evolved Packet Core (EPC) uses Diameter for access to the HSS, PCRF and OCS/OFCS. The HSS is used to obtain subscriber data, and when there are a large number of subscribers, they may be partitioned across multiple HSS instances deployed in the network. Similarly for the PCRF, there may be multiple instances of the PCRF and load balancing is required. Additionally for the PCRF, multiple Diameter interfaces for the same UE/session need to select the same instance; this is called binding. The 3GPP defines the Diameter Routing Agent (DRA) entity to be used to select the correct instance. Similarly the OCS/OFCS requires load balancing across multiple instances. The logic to load balance across multiple instances and to bind requests may be done at the requesting element, e.g., MME, SGSN, AF, PCEF, BBERF. However, this results in an inefficient mesh network that is difficult to manage.

Solution

The Diameter Solution Suite (DSS) can be deployed in the EPC to act as a DRA. All elements connect to the DSS and all Diameter traffic passes through the DSS. The DSS examines the Diameter messages and performs load balancing and binding across the multiple instances of the HSS, PCRF and OCS/OFCS. The DSS may be deployed in a distributed or centralized configuration and optionally in a geographic redundant configuration for disaster recovery. This results in a more efficient network that is easier to manage.

Diametriq, an innovator in Diameter signaling control technologies, offers an exceptional suite of Diameter Signaling Controller (DSC) solutions which can be configured to your specific network requirements.

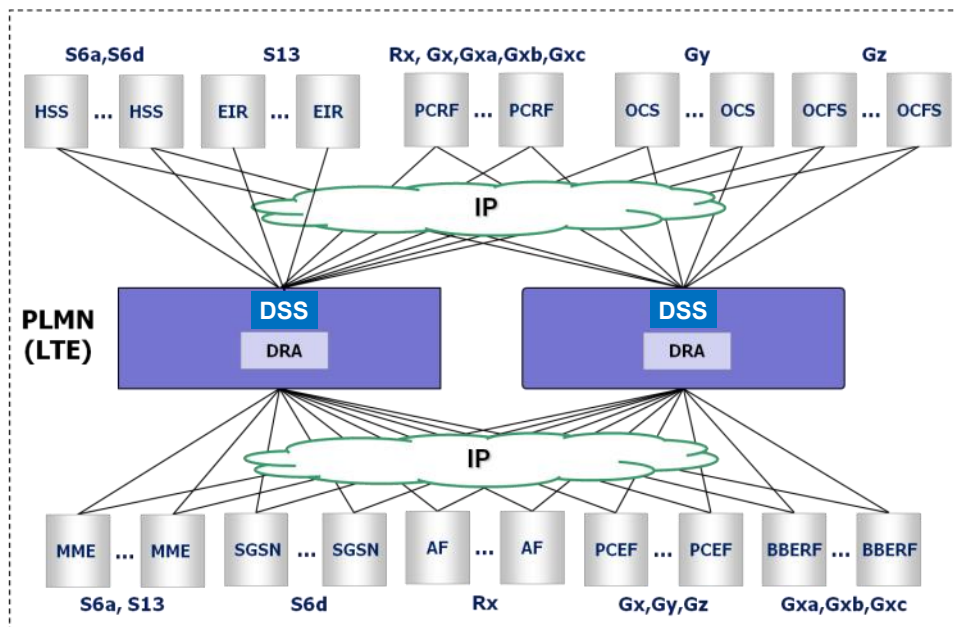

Diameter Solution Suite™



Interconnection Mesh

The Diameter Solution Suite (DSS) can be deployed at the core of the PLMN in a highly scalable, highly available and redundant configuration where all Diameter signaling passes through the DRE resulting in a hub rather than a mesh network.

Roaming and Interconnection

In roaming scenarios where there are multiple MNO's, the DSS is deployed at the edge of the PLMN and performs the Diameter Edge Agent (DEA) role, passing all Diameter signaling through the DSS while performing routing and security functions.

Congestion Control

The DSS detects congestion and can throttle the Diameter signaling passing through the network. The DSS sees all Diameter traffic and can be configured to detect overload and perform overload control on a global or per server basis.

Security

When there are untrusted elements, the DSS provides security at the edge of a PLMN, including DoS, DDoS, NAT with topology hiding and IPsec and TLS for protocols.

Selection and Distribution

When there are multiple Diameter servers (HSS, PCRF, etc.), the DSS selects and distributes across the multiple server instances and sends all messages in a session to the same server. The DSS can act as a proxy or redirect, e.g., the DSS performs the role of a Subscriber Location Function (SLF) for an HSS or a Diameter Routing Agent (DRA) for a PCRF.

Scalability

The DSS has connections to all clients and servers. A client/server instance can be added and a configuration change made at the DSS without other servers or clients being affected.

Interoperability

Vendors of client products need to interoperate with vendors of server products creating a large number interoperability testing combinations. The DSS has connections to all clients and servers, so adding a new vendor only requires interoperability testing with the DSS.

Diameter Interworking

The DSS supports an interworking function (IWF) that interworks between legacy SS7 elements within a PLMN or roaming scenarios that involve a legacy PLMN.

Transport Interworking

The DSS supports an interworking function (IWF) that interworks between Diameter over TCP and Diameter over SCTP.

IP Interworking

The DSS supports an interworking function (IWF) that interworks between Diameter over IPv4 and Diameter over IPv6.

Value-added Applications

The DRE provides a multi-application environment and API to allow new Diameter-based applications to be developed, e.g. Roamer Steering



Corporate Headquarters

1990 W. New Haven Ave.
Suite 303
Melbourne, FL 32904 USA
Tel: + 1 321 726 0686
Fax: + 1 321 726 0683

Development Center

210 Oxford Towers
139 Airport Road
Bangalore - 560017 India