

Diameter Solution Suite™ Use Case

HSS and PCRF Load Balancing and Binding Inter-PLMN (Roaming)

Problem

The Evolved Packet Core (EPC) uses Diameter for access to the HSS and PCRF. The HSS is used to obtain subscriber data and, when there are a large number of subscribers, they may be partitioned across multiple HSS instances deployed in a network. Similarly for the PCRF, there may be multiple instances of the PCRF so load balancing is required. Additionally for the PCRF, multiple Diameter interfaces for the same UE/session need to select the same instance; this is called binding. The 3GPP defines the Diameter Routing Agent (DRA) entity to select the correct instance. Additionally, for roaming where the visited PLMN also supports LTE, there is a need to provide border security and topology hiding at the edge of both the visited and home PLMNs. The GSMA defines the Diameter Edge Agent (DEA) to perform this function. The logic to load balance across multiple instances, bind requests and perform edge security may be done at the requesting element, e.g., MME, SGSN, V-PCRF. However, this results in an inefficient mesh network that is difficult to manage.

Solution

Diametriq, an innovator in Diameter signaling control technologies, offers an exceptional suite of Diameter Signaling Controller (DSC) solutions. The Diameter Solution Suite™(DSS) can be configured to your specific network requirements.

The DSS can be deployed in the EPC to act as a DRA and DEA at the same time. All elements connect to the DRE and all Diameter traffic passes through the DSS. The DSS examines the Diameter messages and performs load balancing and binding across the multiple instances of the HSS and H-PCRF. The DSS is deployed at the edge of the home and visited PLMN and optionally in a geographic redundant configuration for disaster recovery. This results in a more efficient network that is easier to manage.

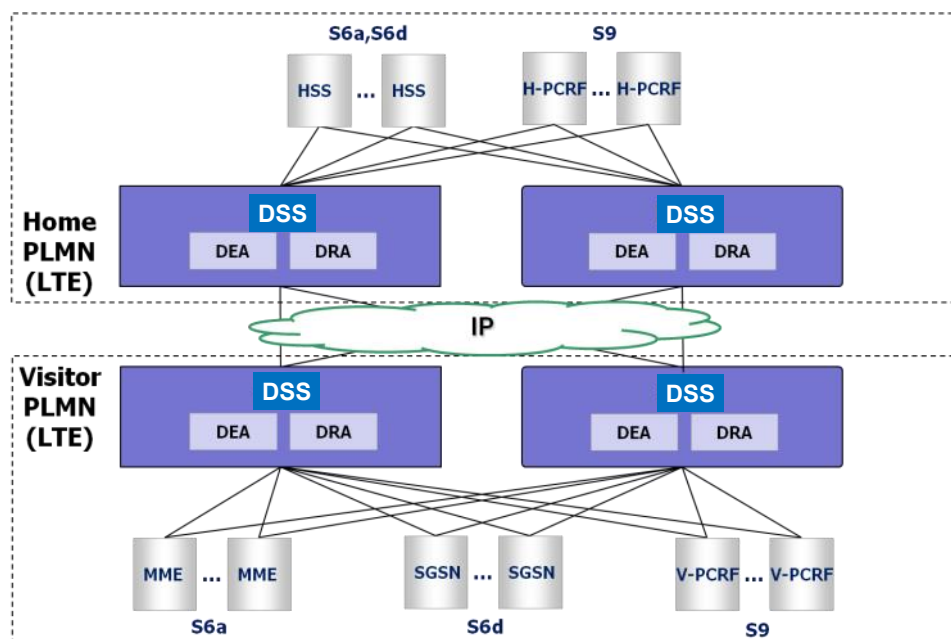

Diameter Solution Suite™



Interconnection Mesh

The Diameter Solution Suite (DSS) can be deployed at the core of the PLMN in a highly scalable, highly available and redundant configuration where all Diameter signaling passes through the DRE resulting in a hub rather than a mesh network.

Roaming and Interconnection

In roaming scenarios where there are multiple MNO's, the DSS is deployed at the edge of the PLMN and performs the Diameter Edge Agent (DEA) role, passing all Diameter signaling through the DSS while performing routing and security functions.

Congestion Control

The DSS detects congestion and can throttle the Diameter signaling passing through the network. The DSS sees all Diameter traffic and can be configured to detect overload and perform overload control on a global or per server basis.

Security

When there are untrusted elements, the DSS provides security at the edge of a PLMN, including DoS, DDoS, NAT with topology hiding and IPsec and TLS for protocols.

Selection and Distribution

When there are multiple Diameter servers (HSS, PCRF, etc.), the DSS selects and distributes across the multiple server instances and sends all messages in a session to the same server. The DSS can act as a proxy or redirect, e.g., the DSS performs the role of a Subscriber Location Function (SLF) for an HSS or a Diameter Routing Agent (DRA) for a PCRF.

Scalability

The DSS has connections to all clients and servers. A client/server instance can be added and a configuration change made at the DSS without other servers or clients being affected.

Interoperability

Vendors of client products need to interoperate with vendors of server products creating a large number interoperability testing combinations. The DSS has connections to all clients and servers, so adding a new vendor only requires interoperability testing with the DSS.

Diameter Interworking

The DSS supports an interworking function (IWF) that interworks between legacy SS7 elements within a PLMN or roaming scenarios that involve a legacy PLMN.

Transport Interworking

The DSS supports an interworking function (IWF) that interworks between Diameter over TCP and Diameter over SCTP.

IP Interworking

The DSS supports an interworking function (IWF) that interworks between Diameter over IPv4 and Diameter over IPv6.

Value-added Applications

The DRE provides a multi-application environment and API to allow new Diameter-based applications to be developed, e.g. Roamer Steering.



Corporate Headquarters

1990 W. New Haven Ave.
Suite 303
Melbourne, FL 32904 USA
Tel: + 1 321 726 0686
Fax: + 1 321 726 0683

Development Center

210 Oxford Towers
139 Airport Road
Bangalore - 560017 India