

Diameter Routing Engine™ (DRE) Use Case

HSS and PCRF Load Balancing and Binding Inter-PLMN (Roaming)

IntelliNet Technologies, a Diameter pioneer and market leader, offers an exceptional suite of Diameter Signaling Controller (DSC) solutions using the Diameter Routing Engine™. The DRE can be configured to your specific network requirements.

Problem

The Evolved Packet Core (EPC) uses Diameter for access to the HSS and PCRF. The HSS is used to obtain subscriber data and, when there are a large number of subscribers, they may be partitioned across multiple HSS instances deployed in a network. The 3GPP defines the SLF entity to be used to select the correct HSS instance. Similarly for the PCRF, there may be multiple instances of the PCRF so load balancing is required. Additionally for the PCRF, multiple Diameter interfaces for the same UE/session need to select the same instance; this is called binding. The 3GPP defines the DRA entity to be used to select the correct instance. Additionally, for roaming where the visited PLMN also supports LTE

there is a need to provide border security and topology hiding at the edge of both the visited and home PLMNs. The GSMA defines the DEA to perform this function. The logic to load balance across multiple instances, bind requests and perform edge security may be done at the requesting element, e.g., MME, SGSN, V-PCEF. However, this results in an inefficient mesh network that is difficult to manage.

Solution

The DRE can be deployed in the EPC to act as a SLF, DRA and DEA at the same time. All elements connect to the DRE and all Diameter traffic passes through the DRE. The DRE examines the Diameter messages and performs load balancing and binding across the multiple instances of the HSS and H-PCRF. The DRE is deployed at the edge of the home and visited PLMN and optionally in a geographic redundant configuration for disaster recovery. This results in a more efficient network that is easier to manage.

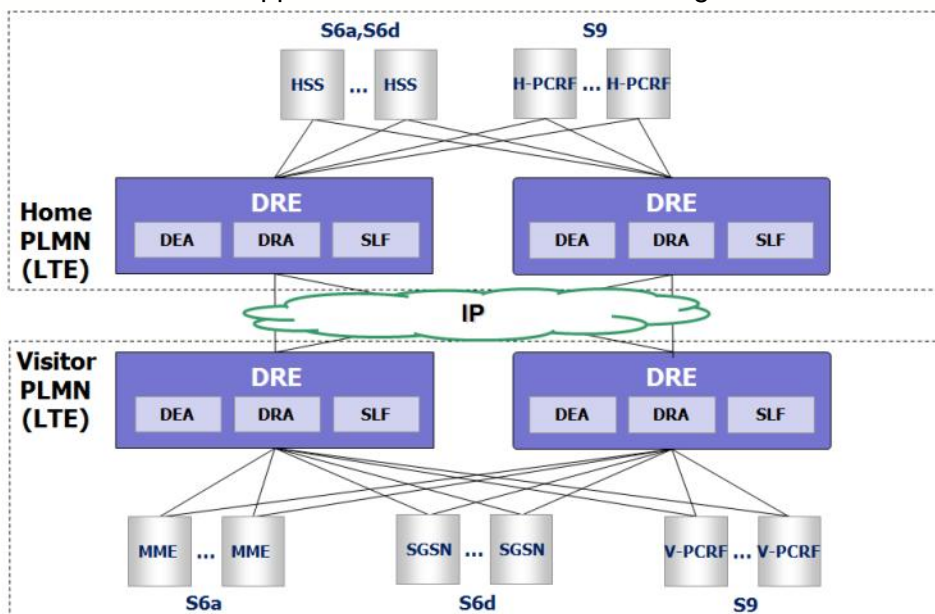

IntelliNet Diameter Routing Engine™

Interconnection Mesh

The DRE is deployed at the core of the PLMN in a highly scalable, highly available and redundant configuration and all Diameter signaling passes through the DRE resulting in a hub rather than a mesh network.

Roaming and Interconnection

In roaming scenarios where there are multiple MNO's, the DRE is deployed at the edge of the PLMN and performs the DEA role, passing all Diameter signaling through the DRE while performing routing and security functions.

Congestion Control

The DRE detects congestion and can throttle the Diameter signaling passing through the network. The DRE sees all Diameter traffic and can be configured to detect overload and perform overload control on a global or per server basis.

Security

When there are untrusted elements, the DRE provides security at the edge of a PLMN, including DoS, DDoS, NAT with topology hiding and IPsec and TLS for protocols.

Scalability

The DRE has connections to all clients and servers. A client/server instance can be added and a configuration change made at the DRE without other servers or clients being affected.

Selection and Distribution

When there are multiple Diameter servers (HSS, PCRF, etc.), the DRE selects and distributes across the multiple server instances and sends all messages in a session to the same server. The DRE can act as a proxy or redirect, e.g., the DRE performs the role of a Subscriber Location Function (SLF) for an HSS or a Diameter Routing Agent (DRA) for a PCRF.

Interoperability

Vendors of client products need to interoperate with vendors of server products creating a large number interoperability testing combinations. The DRE has connections to all clients and servers, so adding a new vendor only requires interoperability testing with the DRE.

Diameter Interworking

The DRE supports an interworking function (IWF) that interworks between legacy SS7 elements within a PLMN or roaming scenarios that involve a legacy PLMN.

Transport Interworking

The DRE supports an interworking function (IWF) that interworks between Diameter over TCP and Diameter over SCTP.

IP Interworking

The DRE supports an interworking function (IWF) that interworks between Diameter over IPv4 and Diameter over IPv6.

Features

- Flexibly rules-based routing using configurable AVPs with AVP modification
- High availability (HA) solution on a single site giving at least 99.999% reliability
- Geographic redundant (GR) solution across multiple sites for disaster recovery (DR)
- Capacity of up to 100K messages/sec per server/blade
- Scalable to 1M messages/sec per cluster
- Linux-based using Intel or ATCA-based server

Benefits

- Simplifies the Diameter network reducing OPEX
- Secures the network from untrusted domains
- Flexible options for inter-operator interconnection
- Easier scaling of the network reducing time and risk
- Centralizes network configuration
- Enables reuse of legacy network elements
- Improves the quality of service of the network



Corporate Headquarters
1990 W. New Haven Ave.
Suite 303
Melbourne, FL 32904 USA

Development Center
210 Oxford Towers
139 Airport Road
Bangalore - 560017 India

Copyright © 2011 IntelliNet Technologies, Inc., all rights reserved. IntelliNet Technologies, Accelerero, Convero and Diameter Routing Engine are trademarks of IntelliNet Technologies, Inc. in the United States and/or other countries. All other trademarks are the property of their respective owners. Specifications are subject to change without notice.

