

Diameter Routing Engine™ (DRE) Use Case

Interworking Diameter between LTE and Legacy for Inter-PLMN (Roaming)

IntelliNet Technologies, a Diameter pioneer and market leader, offers an exceptional suite of Diameter Signaling Controller (DSC) solutions using the Diameter Routing Engine™. The DRE can be configured to your specific network requirements.

Problem

The Evolved Packet Core (EPC) uses Diameter for access to the HSS, EIR and OCS. If the EPC has not been deployed in a PLMN and a subscriber roams into a network where an EPC has been deployed, then queries from the V-PLMN will use Diameter and the H-PLMN has existing legacy elements like the HLR, EIR and Prepaid SCP that use SS7. Conversely, If the EPC has been deployed in a PLMN and a subscriber roams into a network where an EPC has not been deployed, then queries from the V-PLMN will use SS7 and the H-PLMN has EPC elements like the HSS and OCS that use Diameter. In both cases there is a need for an interworking function (IWF) between Diameter and SS7. Additionally, the correct instance of the HLR/EIR, Prepaid SCP, HSS or OCS needs to be selected. The 3GPP defines a IWF between Diameter and MAP, but there is no corresponding standard for

Diameter to CAP. Here the 3GPP defines a SLF selection function. Additionally, there is a need to provide border security and topology hiding at the edge of both the visited and home PLMNs. The GSMA defines the DEA to perform this function.

Solution

The DRE can be deployed in the EPC to act as a DEA, SLF and IWF at the same time. When the MME, SGSN and PCEF use Diameter the DRE selects the correct instance and converts the Diameter (S6a, S6d, S13, Gy) to SS7 (Gr, Gf, Ge) and sends to the HLR/EIR or Prepaid SCP and converts the SS7 response back to Diameter (See figure on left below). When the MSC or SGSN uses SS7 the DRE selects the correct instance and converts the SS7 (Gr, Ge, Gf) to Diameter (S6a, S6d, Gy) and sends to the HSS or OCS and converts the Diameter response back to SS7 (See figure on right below). The DRE may be deployed in a distributed or centralized configuration and optionally in a geographic redundant configuration for disaster recovery. The use of the DRE allows for easy transition from for roaming between PLMN with and without an EPC.

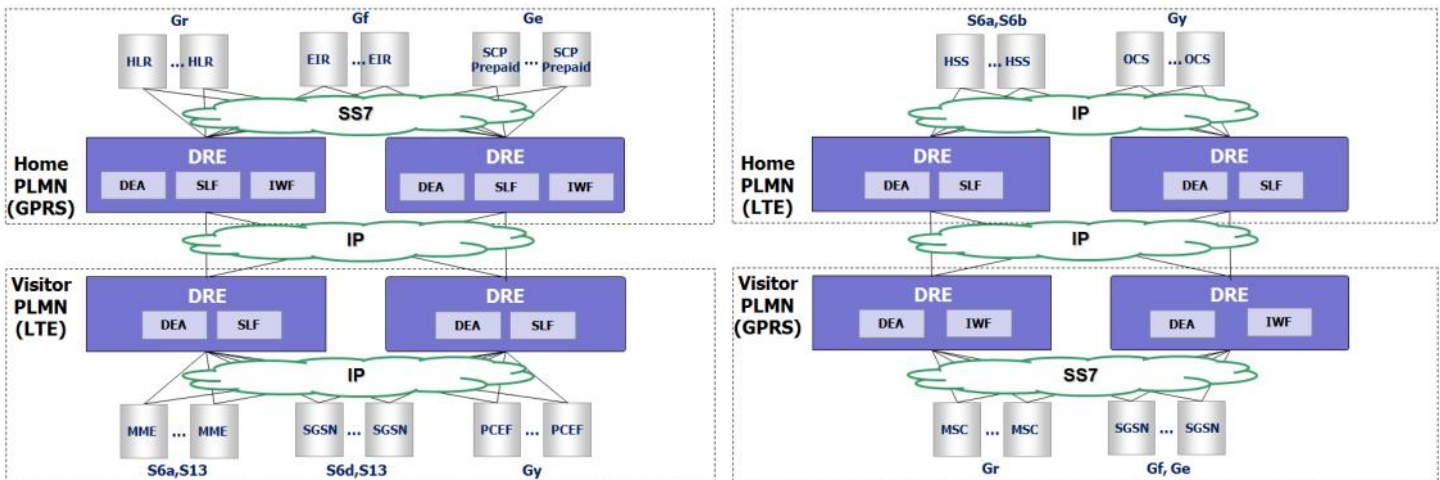

IntelliNet Diameter Routing Engine™

Interconnection Mesh

The DRE is deployed at the core of the PLMN in a highly scalable, highly available and redundant configuration and all Diameter signaling passes through the DRE resulting in a hub rather than a mesh network.

Roaming and Interconnection

In roaming scenarios where there are multiple MNO's, the DRE is deployed at the edge of the PLMN and performs the DEA role, passing all Diameter signaling through the DRE while performing routing and security functions.

Congestion Control

The DRE detects congestion and can throttle the Diameter signaling passing through the network. The DRE sees all Diameter traffic and can be configured to detect overload and perform overload control on a global or per server basis.

Security

When there are untrusted elements, the DRE provides security at the edge of a PLMN, including DoS, DDoS, NAT with topology hiding and IPsec and TLS for protocols.

Scalability

The DRE has connections to all clients and servers. A client/server instance can be added and a configuration change made at the DRE without other servers or clients being affected.

Selection and Distribution

When there are multiple Diameter servers (HSS, PCRF, etc.), the DRE selects and distributes across the multiple server instances and sends all messages in a session to the same server. The DRE can act as a proxy or redirect, e.g., the DRE performs the role of a Subscriber Location Function (SLF) for an HSS or a Diameter Routing Agent (DRA) for a PCRF.

Interoperability

Vendors of client products need to interoperate with vendors of server products creating a large number interoperability testing combinations. The DRE has connections to all clients and servers, so adding a new vendor only requires interoperability testing with the DRE.

Diameter Interworking

The DRE supports an interworking function (IWF) that interworks between legacy SS7 elements within a PLMN or roaming scenarios that involve a legacy PLMN.

Transport Interworking

The DRE supports an interworking function (IWF) that interworks between Diameter over TCP and Diameter over SCTP.

IP Interworking

The DRE supports an interworking function (IWF) that interworks between Diameter over IPv4 and Diameter over IPv6.

Features

- Flexibly rules-based routing using configurable AVPs with AVP modification
- High availability (HA) solution on a single site giving at least 99.999% reliability
- Geographic redundant (GR) solution across multiple sites for disaster recovery (DR)
- Capacity of up to 100K messages/sec per server/blade
- Scalable to 1M messages/sec per cluster
- Linux-based using Intel or ATCA-based server

Benefits

- Simplifies the Diameter network reducing OPEX
- Secures the network from untrusted domains
- Flexible options for inter-operator interconnection
- Easier scaling of the network reducing time and risk
- Centralizes network configuration
- Enables reuse of legacy network elements
- Improves the quality of service of the network



Corporate Headquarters
1990 W. New Haven Ave.
Suite 303
Melbourne, FL 32904 USA

Development Center
210 Oxford Towers
139 Airport Road
Bangalore - 560017 India

Copyright © 2011 IntelliNet Technologies, Inc., all rights reserved. IntelliNet Technologies, Accelerero, Convero and Diameter Routing Engine are trademarks of IntelliNet Technologies, Inc. in the United States and/or other countries. All other trademarks are the property of their respective owners. Specifications are subject to change without notice.

